

POS	CODE	DESCRIPTION (LEFT TO RIGHT)	WIDTH	VOLTAGE	P ELEC [kW]	P GAS [kW]
1	UKVE30	H.E. FISH PAN, 780 X 530 mm	830	230 V	0.10	30.00
2	UKVE30	H.E. FISH PAN, 780 X 530 mm	830	230 V	0.10	30.00
3	UKVE30	H.E. FISH PAN, 780 X 530 mm	830	230 V	0.10	30.00
4	CBC	CHIPBOX HEATED	460	230 V	2.65	0.00
5			0		0.00	0.00
6			0		0.00	0.00
					0.00	0.00
		CABINET 1 HEATED	976.00	230 V	0.90	
		CABINET 2 HEATED	976.00	230 V	0.90	
		CABINET 3 HEATED	976.00	230 V	0.90	
		RANGE		230 V	2.50	
		TOTAL			8.15	90.0

Perfecta Counter Range

Includes batterbox



Includes mobile scrapbox

Extraction: Not specified
Waste oil at the right

Basketrail on all pans
4 Baskets

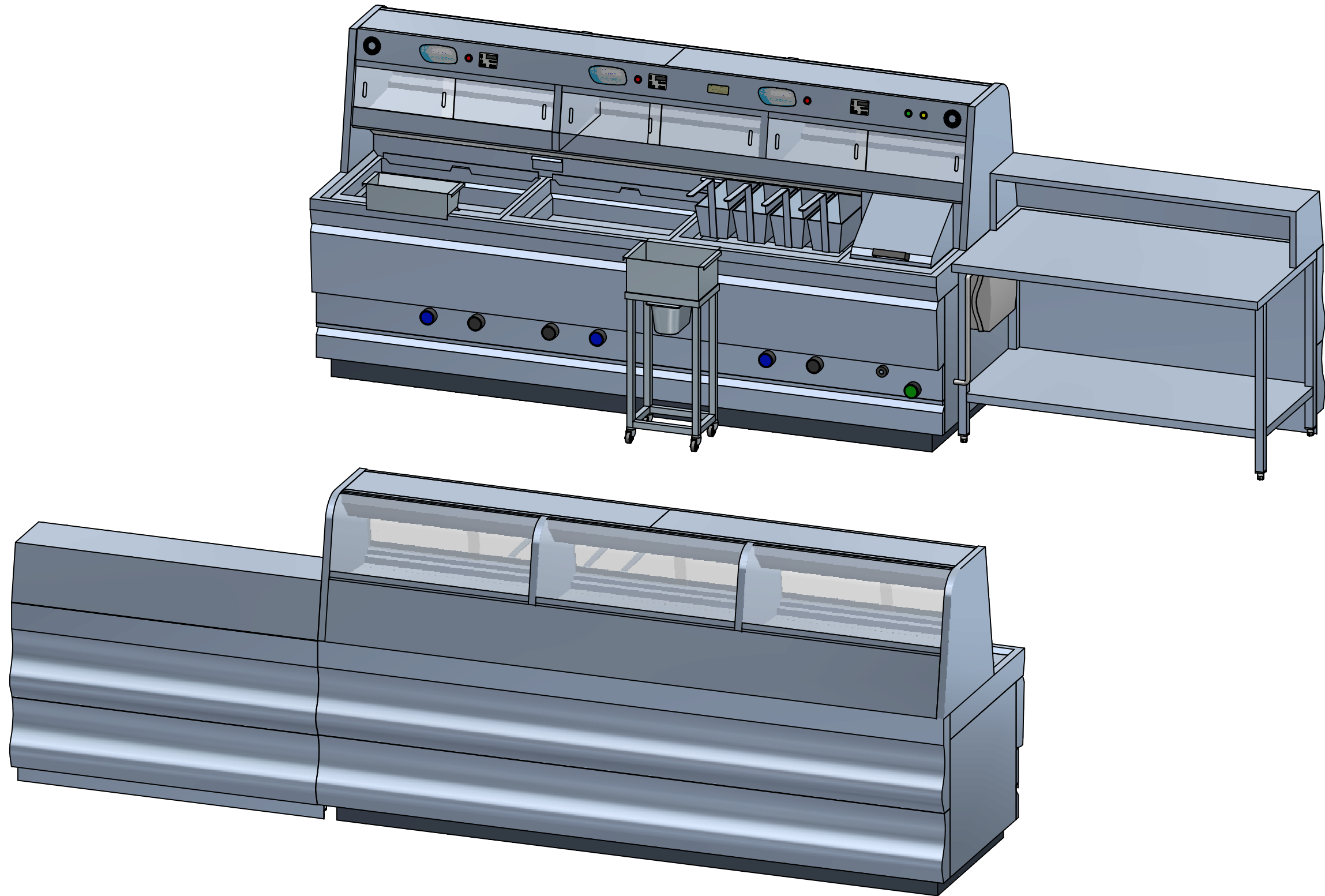
Copyright according to Law	Customer		Location		Agency	
	-		-			
	! Amerikase Proj	Drawing number		COUNTER NR 3		
		Page 1 of 2				
	⊕	Salesperson				
Tol:		Date	28-01-2013			
5 mm		Drawn by	Pim van Stipdonk			
PERFECTA		QBTEC BV				Approved
		Middellandse Zee 9				
		3446 CG Woerden Holland				
		Tel.: +31 (0)348 475555 Fax: +31 (0)348 418495 info@qbtec.nl www.qbtec.nl				



Copyright according to Law	Customer	-		Location	-		Agency		
	 Drawing number  Page 2 of 2 COUNTER NR 3	Salesperson				 QBTEC BV Middellandse Zee 9 3446 CG Woerden Holland Tel.: +31 (0)348 475555 Fax: +31 (0)348 418495 info@qbtec.nl www.qbtec.nl		Approved	
		Tol:	Date	28-01-2013					
	5 mm	Drawn by	Pim van Stipdonk						